

Cooling Capacity: 51 to 264 kW



Applications

- Cool down process water**
- Injection molding equipments**
- Air conditioning of manufacturing and office rooms**
- Food processing industry**
- Chemical industry – gas separation and chemical processing**
- Industrial process equipment - oil cooling, metal processing and metal treatment**

Features

- Minimized foot print
- Easy installation
- High reliability and endurance
- Capacity control, cost effective operation
- Air or water cooled condenser
- Microprocessor controlled and optimized compressor run time
- Flow switch
- For indoor applications
- Optional accessories

Standard Unit Features

- One refrigeration circuit furnished with two compressors (semihhermetic or hermetic scroll type)
- Compressor protection against start-up cycling
- Capacity control (0, 50, 100%) with optimized compressor run time
- Fluid temperature control
- Full automatic operation with fluid freezing protection
- Automatic power supply phase rotation
- Step by step compressor run-up
- Monitoring compressors working hours
- High and low pressure unit protection switch
- High efficient shell tube evaporator with thermal insulation
- Electric control box with build in controller and main power switch
- CE conformity declaration

Optional Accessories

- Air cooled condenser (remote)
- Water cooled condenser (built-in)
- Receiver tank
- Electric crankcase oil heater
- Electronic expansion valve
- Remote unit control panel
- Condenser fans speed control
- Water pump control including power supply
- Reduced unit noise level (for hermetic scroll compressors only)
- Air cooled condenser with noise level reduced
- Heat recovery set
- Water accumulator tank with circulation pump



Unit controller



Remote control panel



Technical Specification

Series of WTE units are designated for indoor application where minimal foot print is required. Unit even easy pass through single wing doors. In matter to additionally reduce unit profile, electrical control box can be separated for transport. Short unit design circuiting allow to minimize refrigerant charge.

Unit can be equipped either with air or water cooled condenser. Next selection of optional accessories is available along units. Optionally units are equipped with hermetic scroll compressors (WTE-S2) or semihermetic piston compressors (WTE-X2).

Model	WTE-S2				WTE-X2						
	50	60	70	80	100	120	140	180	200	230	
Cooling Power ⁽¹⁾	kW	51	59	73	89	99	124	147	180	219	264
Water Flow ⁽²⁾	m ³ /h/bar	8.8/0.24	10.2/0.23	12.6/0.27	13.3/0.13	17.1/0.45	21.4/0.22	25.3/0.21	31.0/0.29	37.7/0.23	45.5/0.34
Power Input ⁽³⁾	kW	12	13.6	17.2	20.6	24.8	31.6	39	48.8	58.2	66.2
Power Supply		230/400V - 3 ⁻ - 50Hz				230/400V - 3 ⁻ - 50Hz					
Current ⁽⁴⁾	A	26.6	27.4	31.4	38.6	45	57.6	68.2	89.2	102.6	136.1
Hight H ⁽⁵⁾	mm	1170/1515	1185/1530	1185/1550	1185/1585	1065/1425			1120/1480	1190/1550	1315/1675
Depth B	mm	795				799			850		
Width A	mm	1750	1950	2000	2125	2380	2090	2610	2920	2115	2920
Water Connection		DN 65			DN 80	DN 80		DN 100		DN 125	
Weight ⁽⁶⁾	kg	456	469	479	537	723	768	817	919	1024	1203
Noise ⁽⁷⁾	dB(A)/1m	70		72		73	74	73	80		

⁽¹⁾ Water 7/12°C, 40°C condensing temperature, R407C refrigerant; capacity data for different conditions and refrigerant on request

⁽²⁾ Nominal water flow at 7/12°C and corresponding pressure drop (bar)

⁽³⁾ Compressor power input at conditions ⁽¹⁾

⁽⁴⁾ Compressors operation current without condenser at conditions ⁽¹⁾

⁽⁵⁾ Unit height without/with receiver tank

⁽⁶⁾ Unit weight – without condenser, receiver and charges

⁽⁷⁾ Unit sound pressure level Lp (dB (A) (compressors only) in 1m distance

Illustrative picture

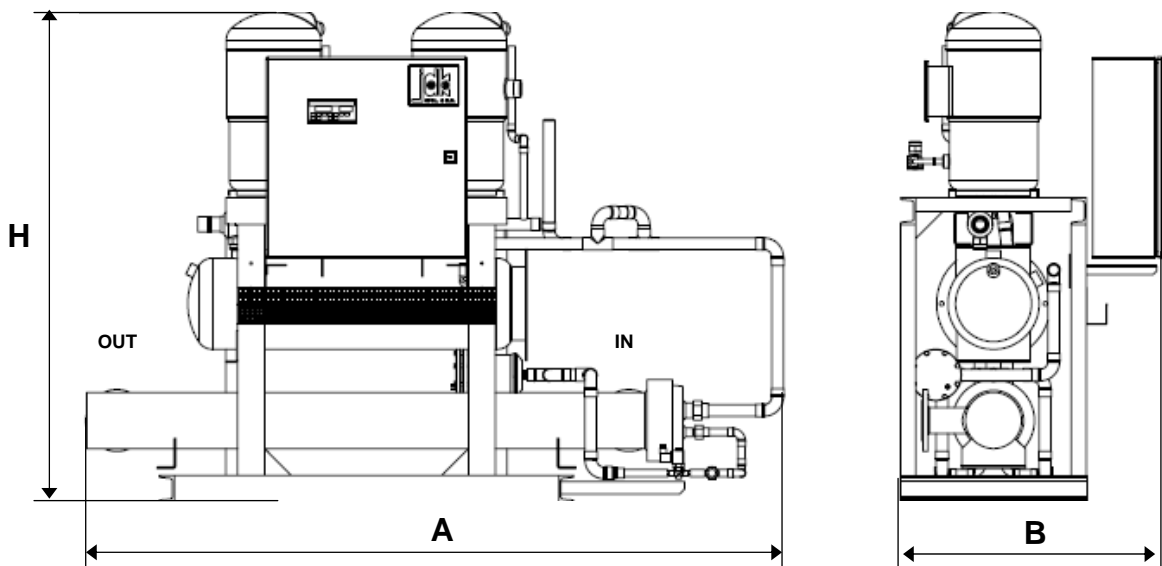

JDK, spol. s r.o.

Pražská 2161
288 02 Nymburk
Czech Republic

Tel: +420 325 519 111; +420 325 512 315

Fax: +420 325 514 718

E-mail: jdk@jdk.cz

JDK Slovakia, spol. s r.o.

Novozamocká 179
949 05 Nitra
Slovak Republic

Tel: +421 376 514 311; +421 376 523

Fax: +421 376 555 858

E-mail: jdk@jdk.sk